

Powered Industrial Trucks - Program & Operator Training Requirements

OSHA Standards:
1910.178 (l)
1915.120 (a)
1917.1 (a)(2)(xiv)
1918.1 (b)(10)
1926.602 (d)

University of Rochester

Environmental Health and Safety

What is a Powered Industrial Truck?



- A **mobile, power-propelled** truck used to carry, push, pull, lift, stack or tier materials.
- Commonly known as forklifts, pallet trucks, rider trucks, forktrucks, or liftrucks.
- Excluded are vehicles used for earth moving and over-the-road hauling.
- Can be powered through electric or combustion engines.

Powered Industrial Trucks

- Environmental Health and Safety has an inventory of powered industrial trucks. If you have these machines, you must contact EHS to be added to the inventory.
- The following slides give the basics of OSHA's requirements for these machines. Contact EHS for specifics.

Performance-Oriented Requirements

- The powered industrial truck operator training requirements are performance-oriented to permit employers to tailor a training program to the characteristics of their workplaces and the particular types of powered industrial trucks operated.
- Employees must demonstrate safe use on the truck.



Training Employees



- Employee Certification can be obtained by:
 - ◆ Having the supplier of the the truck provide OR
 - ◆ Having Environmental Health and Safety provide training OR
 - ◆ Providing training yourself by a competent person as defined by OSHA
- In all cases, you will be responsible to verify that the employee is certified in addition to whoever does the training

Operator Training

■ Safe operations

- ◆ The employer shall ensure that each powered industrial truck operator is competent to operate a powered industrial truck safely, as demonstrated by successful completion of the training and evaluation specified in the OSHA standard.
- ◆ Prior to permitting an employee to operate a powered industrial truck (except for training purposes), the employer shall ensure that each operator has successfully completed the required training (or previously received appropriate training).

Training Program Implementation

- Trainees may operate a powered industrial truck only:
 - ◆ Under direct supervision of a person who has the knowledge, training, and experience to train operators and evaluate their competence; and,
 - ◆ Where such operation does not endanger the trainee or other employees.

Training Program Implementation

(continued)

- Training shall consist of a combination of:
 - ◆ Formal instruction (e.g., lecture, discussion, interactive computer learning, written material),
 - ◆ Practical training (demonstrations and exercises performed by the trainee), and
 - ◆ Evaluation of the operator's performance in the workplace

Training Program Implementation (continued)

- Training and evaluation shall be conducted by a person with the knowledge, training and experience to train powered industrial truck operators and evaluate their competence.



Effective Powered Industrial Truck Operator Training Program

- Four major areas of concern must be addressed:
 - ◆ The general hazards that apply to the operation of all or most powered industrial trucks;
 - ◆ The hazards associated with the operation of particular types of trucks;
 - ◆ The hazards of workplaces generally; and,
 - ◆ The hazards of the particular workplace where the vehicle operates.

Training Program Content

- Operators shall receive initial training in the following topics:
 - ◆ Truck-related topics
 - ◆ Workplace-related topics
 - ◆ The requirements of the standard



Training Program Content (continued)

■ Truck-related topics

- ◆ Operating instructions, warnings and precautions
- ◆ Differences from automobile
- ◆ Controls and instrumentation
- ◆ Engine or motor operation
- ◆ Steering and maneuvering
- ◆ Visibility
- ◆ Fork and attachment adaptation, operation, use
- ◆ Vehicle capacity and stability
- ◆ Vehicle inspection and maintenance that the operator will be required to perform
- ◆ Refueling/Charging/Recharging batteries
- ◆ Operating limitations
- ◆ Other instructions, etc.

Training Program Content (continued)

■ Workplace-related topics

- ◆ Surface conditions
- ◆ Composition and stability of loads
- ◆ Load manipulation, stacking, unstacking
- ◆ Pedestrian traffic
- ◆ Narrow aisles and restricted areas
- ◆ Operating in hazardous (classified) locations
- ◆ Operating on ramps and sloped surfaces
- ◆ Potentially hazardous environmental conditions
- ◆ Operating in closed environments or other areas where poor ventilation or maintenance could cause carbon monoxide or diesel exhaust buildup

Training Program Content (continued)

- The requirements of the OSHA standard on powered industrial trucks must also be included in the initial operator training program.

Refresher Training and Evaluation

- Refresher training, including an evaluation of the effectiveness of that training, shall be conducted to ensure that the operator has the knowledge and skills needed to operate the powered industrial truck safely.
- Refresher training required when:
 - ◆ Unsafe operation
 - ◆ Accident or near-miss
 - ◆ Evaluation indicates need
 - ◆ Different type of equipment introduced
 - ◆ Workplace condition changes

Refresher Training and Evaluation (continued)

- An evaluation of each powered industrial truck operator's performance must be conducted:
 - ◆ After initial training,
 - ◆ After refresher training, and
 - ◆ At least once every three years

Certification

- The employer shall certify that each operator has been trained and evaluated as required by the standard.
- Certification shall include:
 - ◆ Name of operator
 - ◆ Date of training
 - ◆ Date of evaluation
 - ◆ Identity of person(s) performing the training or evaluation

Stability Triangle - Figure 1

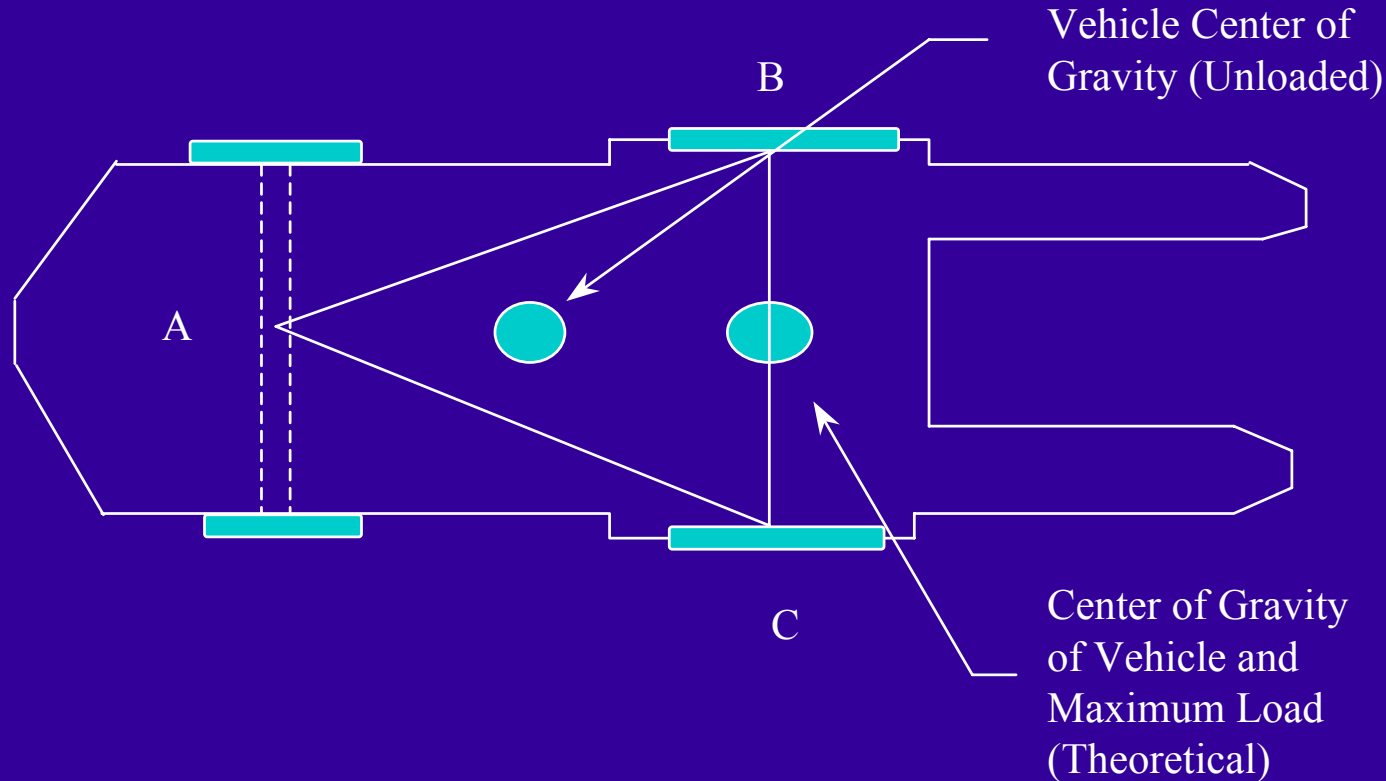

Notes:

1. When the vehicle is loaded, the combined center of gravity (CG) shifts toward line B-C. Theoretically the maximum load will result in the CG at the line B-C. In actual practice, the combined CG should never be at line B-C.
2. The addition of additional counterweight will cause the truck CG to shift toward point A and result in a truck that is less stable laterally.

Stability Triangle - Figure 2

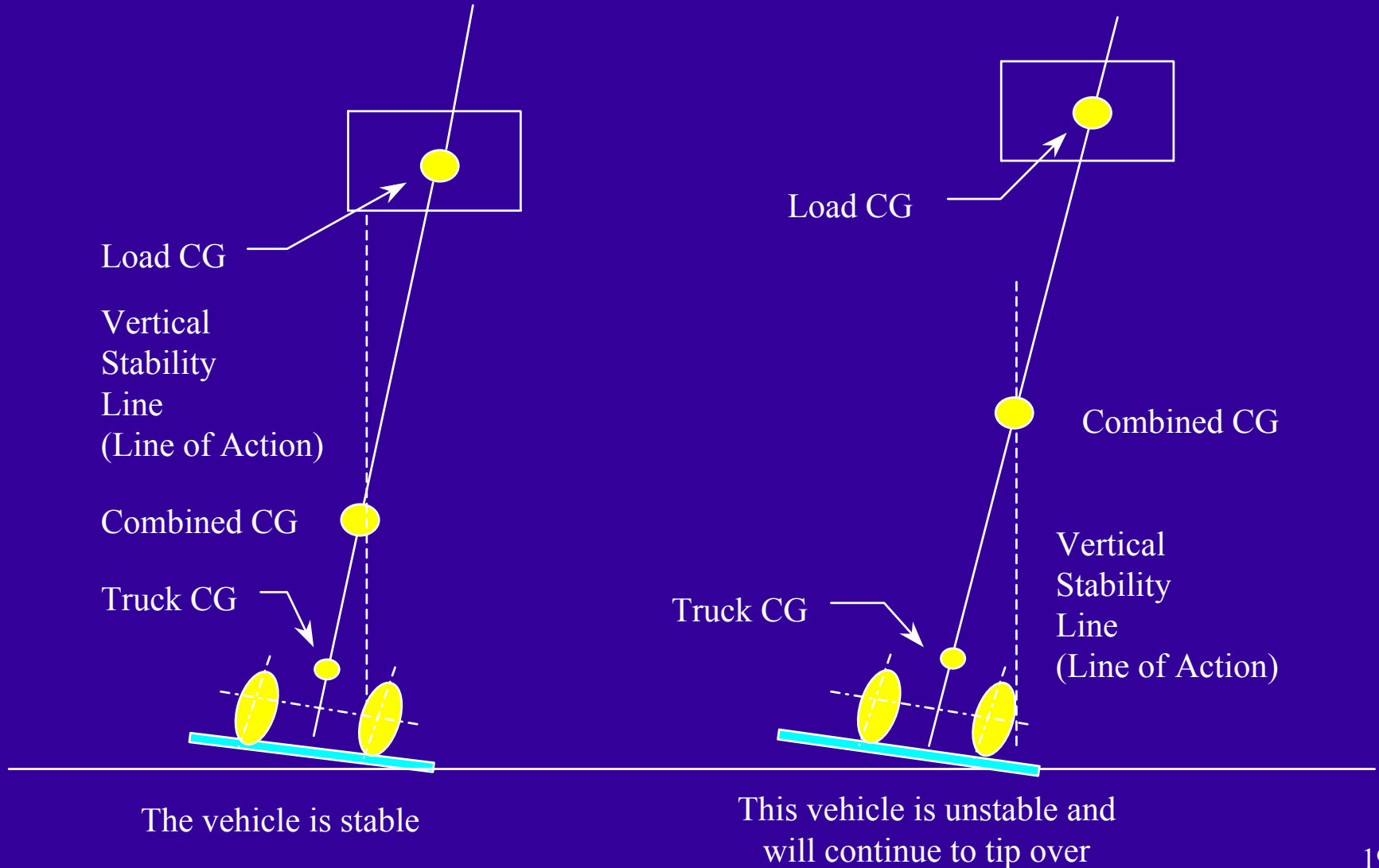

Types of Powered Industrial Trucks

- There are many different types of powered industrial trucks covered by the OSHA standard.
- Commonly used types include:
 - ◆ High lift trucks, counterbalanced trucks, cantilever trucks, rider trucks, forklift trucks, high lift trucks, high lift platform trucks, low lift trucks, motorized hand trucks, pallet trucks, straddle trucks, reach rider trucks, high lift order picker trucks, motorized hand/rider trucks, and counterbalanced front/side loader lift trucks.
- A single type of truck can only be described by calling it by all of its characteristics, (e.g., a high lift, counterbalanced, sit down rider truck).

Unique Characteristics of Powered Industrial Trucks

- Each type of powered industrial truck has its own unique characteristics and some inherent hazards.
- To be effective, training must address the unique characteristics of the type of vehicle the employee is being trained to operate.

Components of a Forklift Truck*

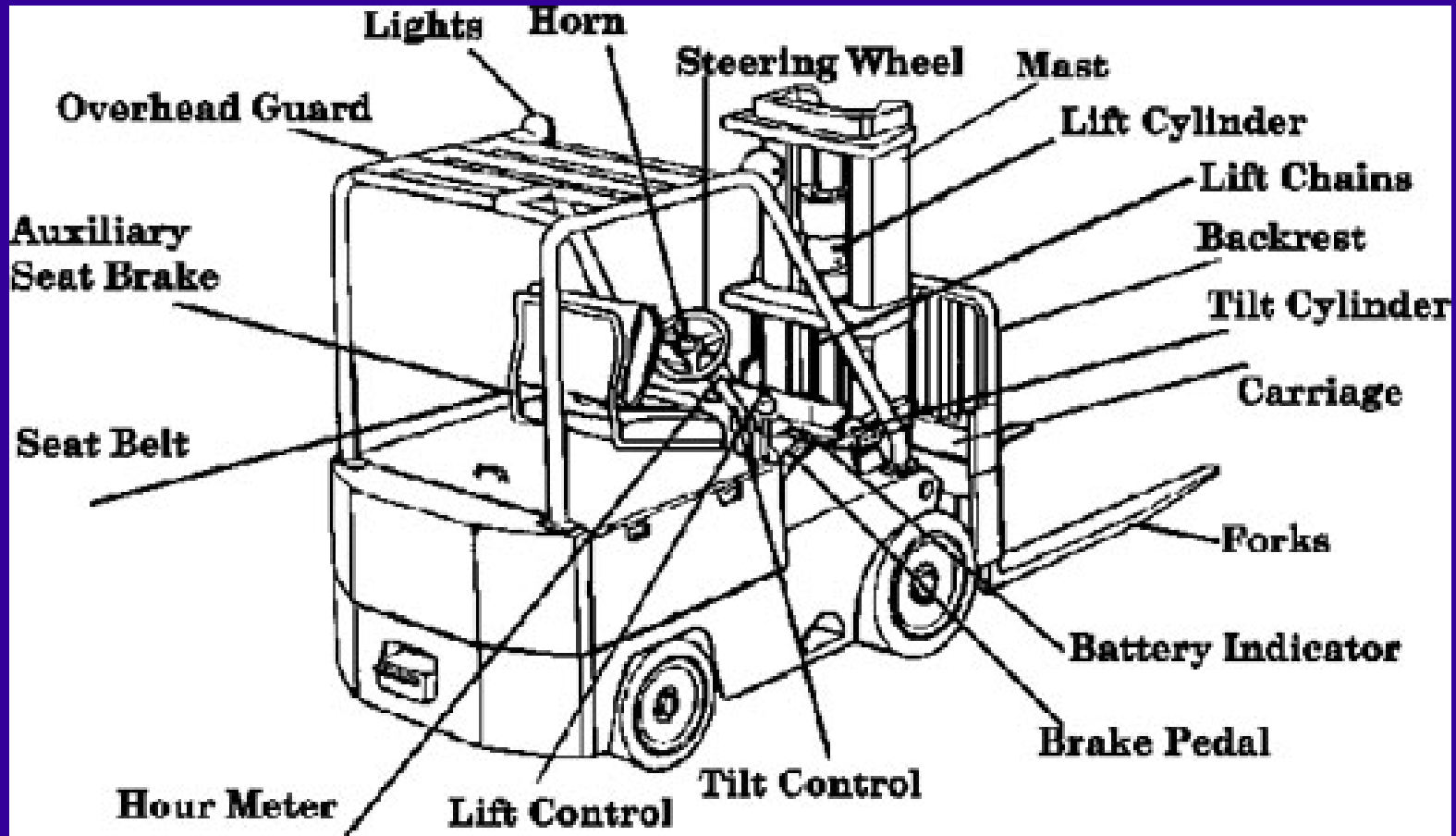

*One of the most common types of powered industrial trucks

Class I - Electric Motor Rider Trucks

- Counterbalanced rider type, stand up
- Three wheel electric trucks, sit-down
- Counterbalanced rider type, cushion tires, sit-down (high and low platform)
- Counterbalanced rider, pneumatic tire, sit-down (high and low platform)

Class I - Electric Motor Rider Trucks

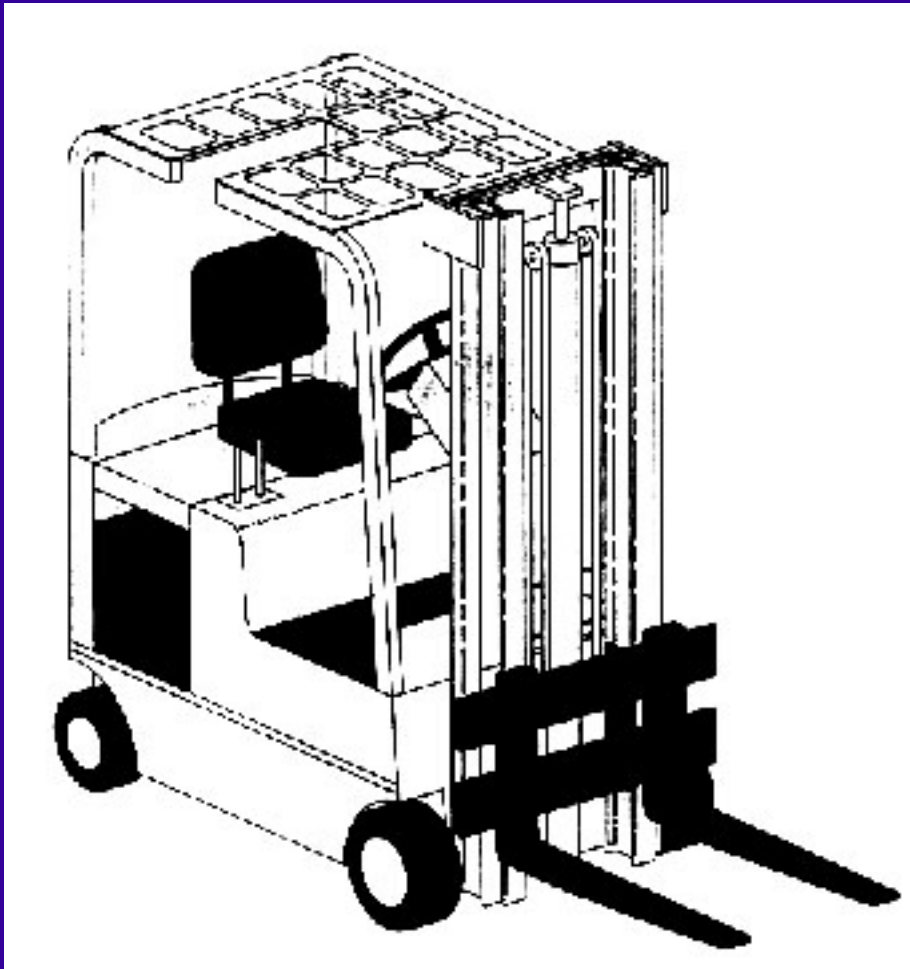

Sit Down Rider - Electric

Class I - Electric Motor Rider Trucks



- Counterbalanced Rider Type, Stand-Up

Class II - Electric Motor Narrow Aisle Trucks

- High lift straddle
- Order picker
- Reach type outrigger
- Side loaders, turret trucks, swing mast and convertible turret/stock pickers
- Low lift pallet and platform (rider)

Class II - Electric Motor Narrow Aisle Trucks

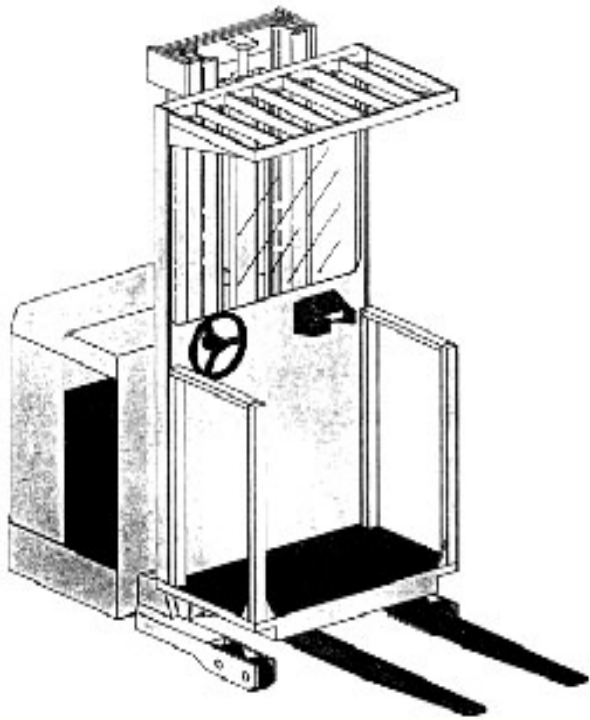

Order Picker

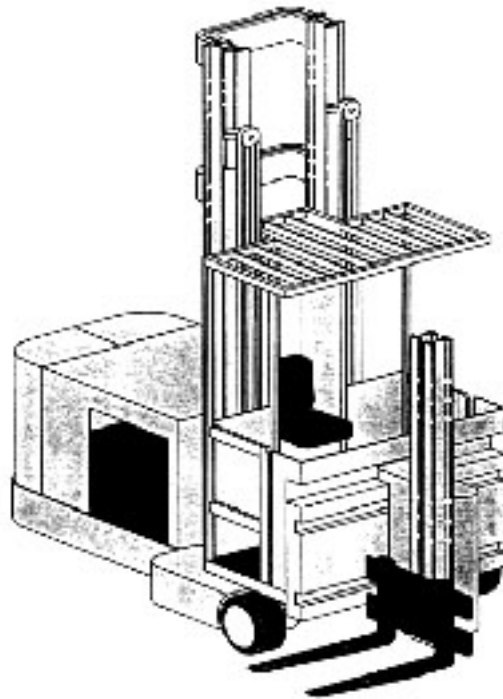

Turret Truck

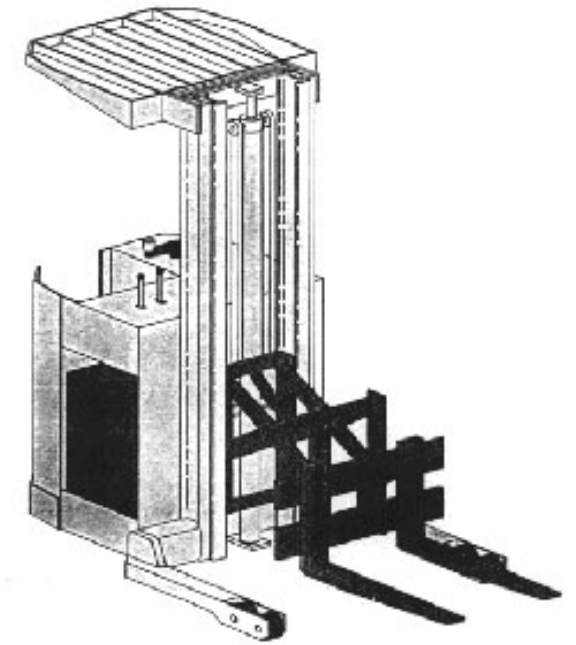

**Reach Type
Outrigger**

Class III - Electric Motor Hand or Hand/Rider Trucks

- Low lift platform
- Low lift walkie pallet
- Reach type outrigger
- High lift straddle
- High lift counterbalanced
- Low lift walkie/rider pallet

Class III - Electric Motor Hand or Hand/Rider Trucks

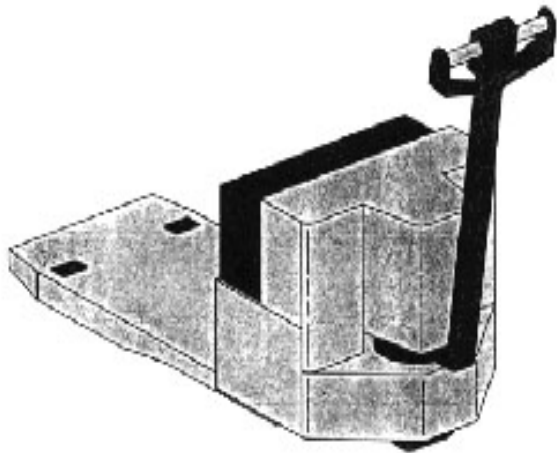

Low Lift Platform

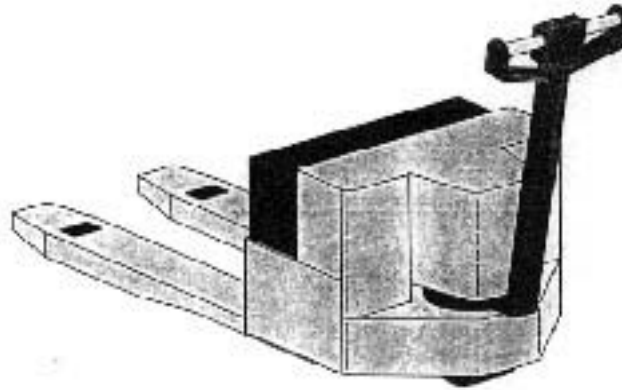

**Low Lift
Walkie Pallet**

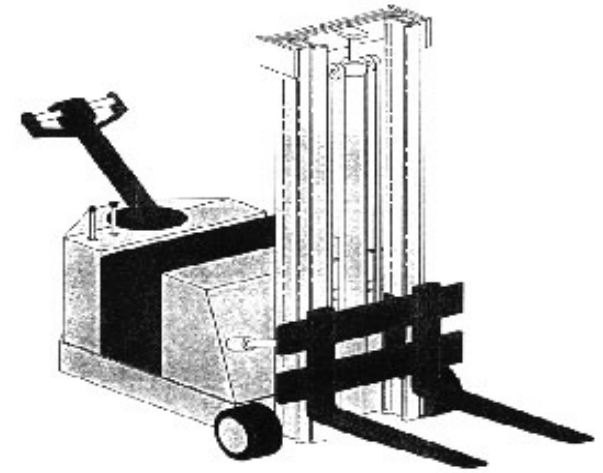

**High Lift
Counterbalanced**

Class IV - Internal Combustion Engine Trucks - Cushion (Solid) Tires

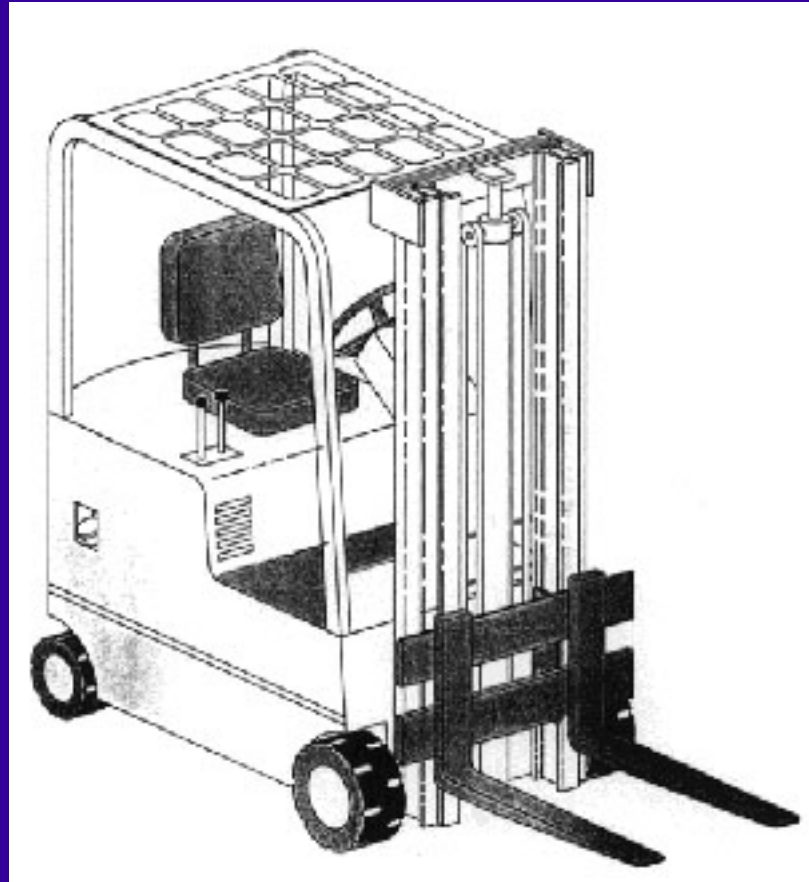

Fork, counterbalanced (cushion/solid tires)

Class V - Internal Combustion Engine Trucks - Pneumatic Tires

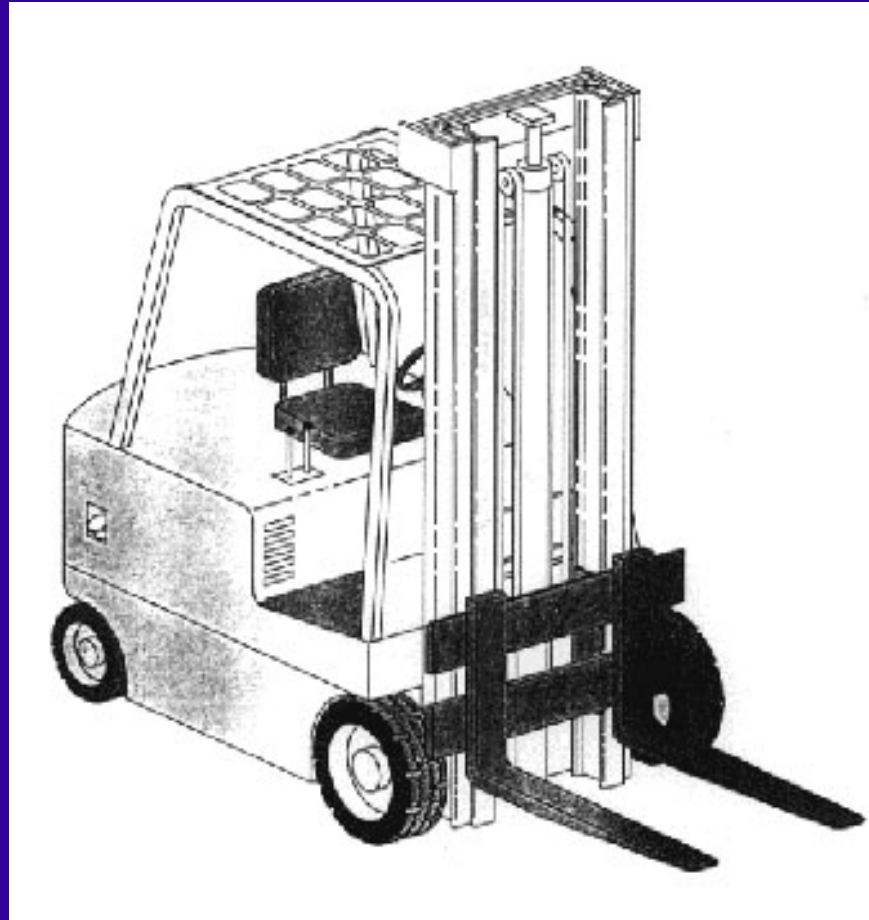

Fork, counterbalanced (pneumatic tires)

Class VI - Electric & Internal Combustion Engine Tractors

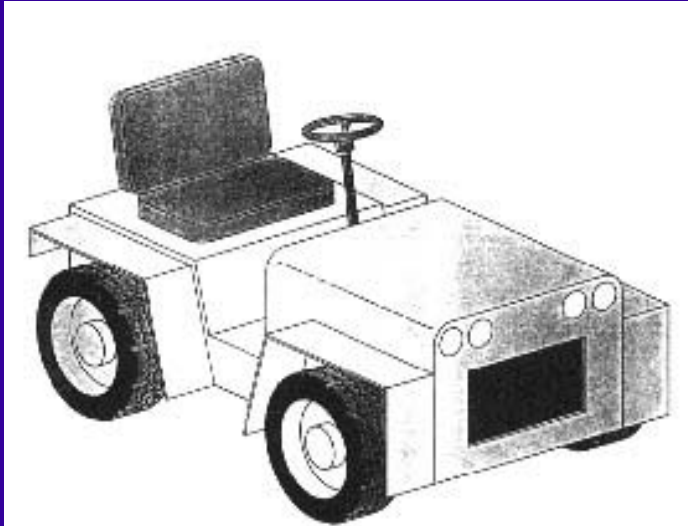

Sit-down rider